

MotorGuide® REPAIR PARTS

Model:
ST350

SPECIFICATIONS:

Year 1996
 Thrust 41LBS
 Volts 12VDC
 Amp Draw 0 to 48amps
 Mount 03
 Speeds 5/2

PARTS ORDERING & TECH ASSISTANCE

MotorGuide Consumer Relations
 Phone 918-831-6989
 Fax 800-982-8093

Send Returned Goods to:

MotorGuide
 605 Hwy 12 West
 Starkville, MS 39760

Returned Goods must be accompanied with a Returned Goods Authorization. Contact MotorGuide Consumer Relations to obtain RGA.

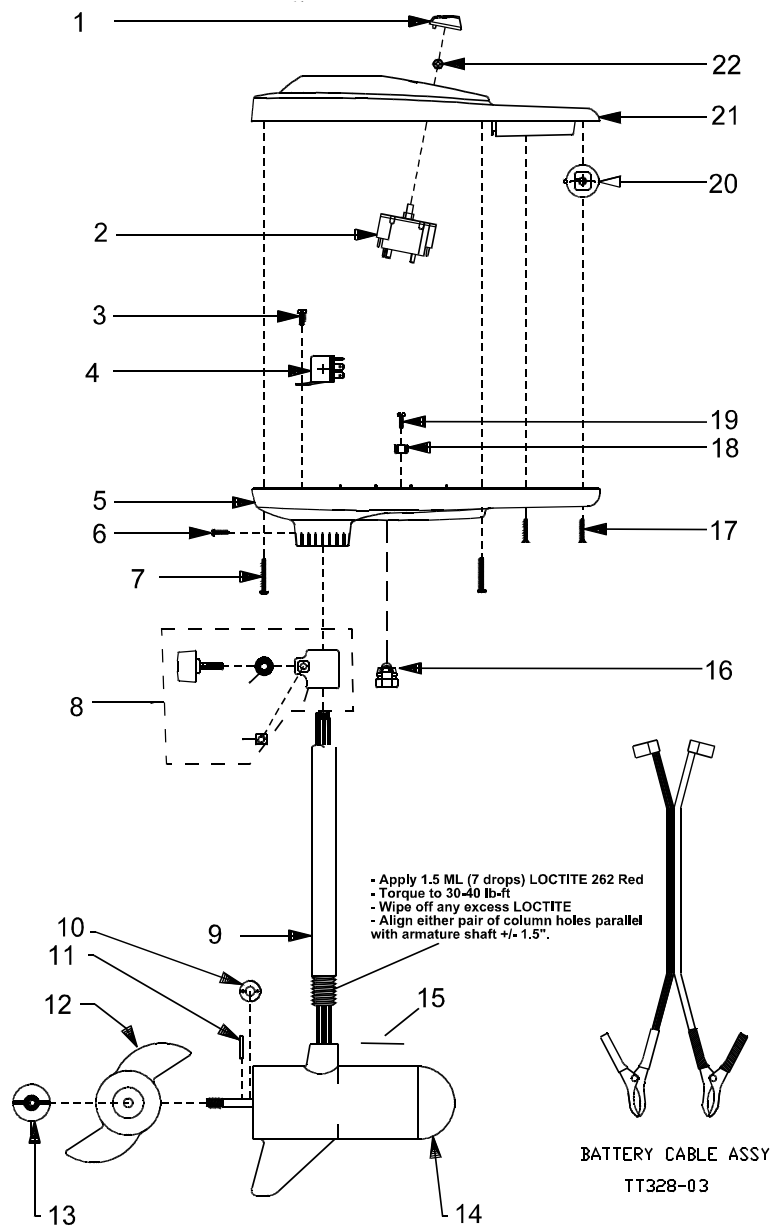

KEY	DESCRIPTION	PART #
1	KNOB	TT082-07
2	ROTARY SWITCH	KT150-02
3	#10x 1/2" SCREW	GR133-01
4	RELAY	TT128-01
5	T/H BASE BLACK	TT004-06
6	8 X 1-3/8 SCREW	AR133-01
7	8 X 1-3/8 SCREW	AR133-01
8	DEPTH COLLAR ASY	AR158-01
9	30" COLUMN	TT049-01
10	MONOFILAMENT WASHER	AR175-01
11	PROP DRIVE PIN	BR102-01
12	PROP	AF124-10
13	PROP NUT	AR099-01
14	5 SP MOTOR	DF397-02
15	MARINE LOWER UNIT DECAL	ET060-04
16	GROMMET	GR019-03
17	#4x 1" SCREW	TT141-02
18	TERMINAL	FT160-03
19	#10x 1/2" SCREW	GR133-01
20	ON/OFF HANDLE ASSY	TT372-01
21	T/H COVER	KT053-11
22	NUT	AT098-01

PARTS NOT ILLUSTRATED
 NOMENCLATURE DECAL FR056-08

LOWER UNIT BREAKDOWN

Model:
ST350

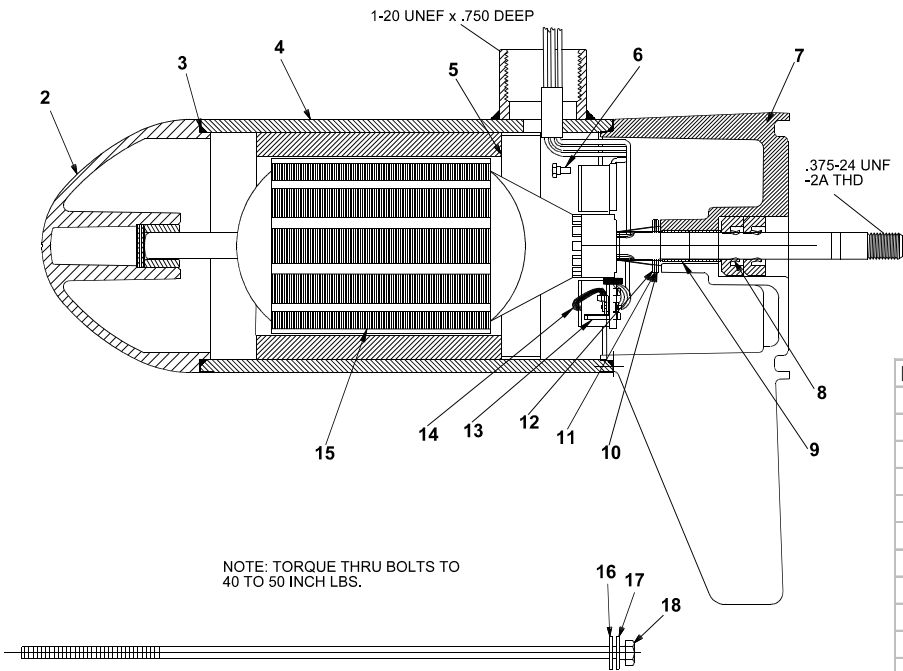

NOTE: TORQUE THRU BOLTS TO 40 TO 50 INCH LBS.

KEY #	QTY	DESCRIPTION	PART NO.
1	X	MOTOR	DF397-02
2	1	NOSE CAP	JF3212-01
3	2	O RING SEAL	MR217-01
4	1	HOUSING ASSY	JF3210-01
5	1	RETAINER	JF233-01
6	2	BRUSH CARD SCREW	MR228-01
7	1	COMM CAP	DF3205-01
8	2	SHAFT SEAL	MR223-01
9	1	BEARING	MR206-01
10	1	NYLATRON WASHER	MR226-01
11	1	WASHER	MR227-01
12	1	E RING	MR219-01
13	2	BRUSH SPRINGS	MR214-02
14	1	BRUSH ASSY LESS SPRING	DF3201-01
15	1	ARMATURE 3.5"	CF3207-01
16	4	STATIC SEAL	MR222-01
17	4	THRU BOLT WASHER	MR216-01
18	2	THRU BOLT	MR218-02

WIRING

